

Frullatore frappè mod.FR1G-2G & FR1P-2P
Milkshaker mod.FR1G-2G & FR1P-2P

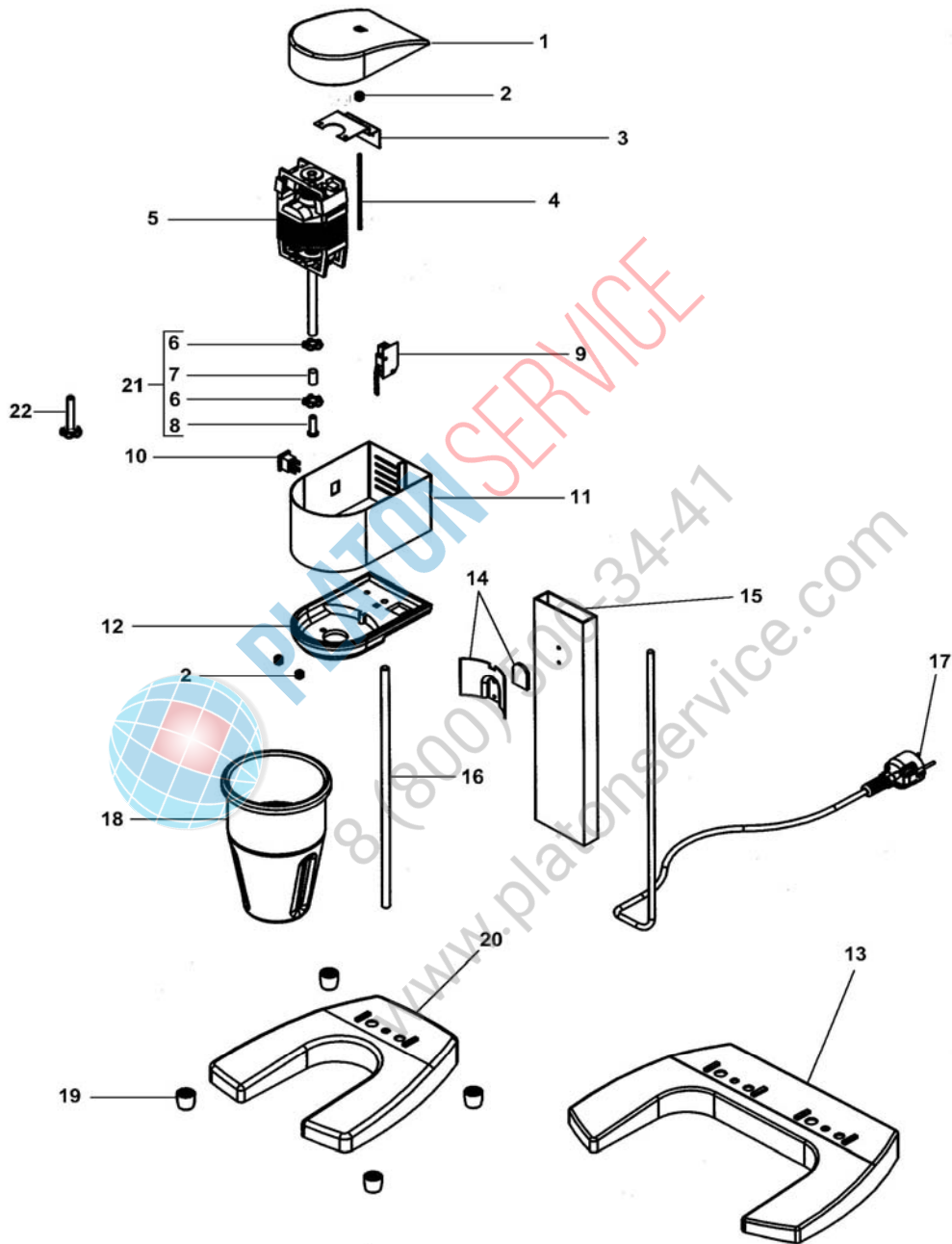

**FRULLATORE FRAPPE' MOD.FR1G-2G & FR1P-2P
MILKSHAKER MOD.FR1G-2G & FR1P-2P**

Rif No	Codice Code	Caratteristiche Characteristics	Descrizione Description
1	CO1670		Copertura Covering
2	CO1658		Distanziale Spacer
3	CO1668		Supporto Support
4	CO1667		Distanziale Spacer
5	CO1665	230V/1Ph/50-60Hz	Motore Motor
6	CO1664	01/01/03 f.p.(*)	Ventola Fan
7	CO1663	01/01/03 f.p.(*)	Boccola Bush
8	CO1662	01/01/03 f.p.(*)	Inserto Insert
9	CO1666	⊕	Micrinterruttore Microswitch
10	CO1661	⊕	Interruttore Switch
11	CO1660		Carcassa Housing
12	CO1659		Coperchio Cover
13	CO1491		Base Base
14	CO1496		Supporto Support
15	CO1495		Supporto Support
16	CO1493		Tubo Tube
17	CO1494	1Ph+N+Gnd	Cavo elettrico Electric cable
18	CO1076	(FR1G-2G) Stainless steel	Contentitore Tank
18	CO1492	(FR1P-2P) Plastic	Contentitore Tank
19	CO1460		Piedino Foot
20	CO1490		Base Base
21	CO1934	01/01/03 f.p.(*) Assembly - Stainless steel	Mescolatore Mixer
22	CO2816	⊕ Assembly - Plastic	Mescolatore Mixer

(*): fuori produzione / out of production

⊕ : ricambio consigliato / spare part suggested



PLATON SERVICE
8 (800) 500-34-41
www.platonservice.com